

CATALOG NO.	CONDUCTOR		BOLT SIZE	INSTALLATION TOOLING (# CRIMPS)										DIELESS (# CRIMPS)	WIRE STRIP LENGTH
	CODE (AWG)	NAVY		DIE INDEX	COLOR CODE	MECHANICAL RATCHET			HYDRAULIC						
						MD7-34R MD6	OUR840	Y1MRTC \triangleleft 5	Y34A \triangleleft 8	Y750, Y35, Y39	Y46 \triangleleft 4	Y45 \triangleleft 3			
YAZ6C2TC38E16	#6 AWG [-----]	30	3/8 [M10]	7 OR 374	BLUE	W5CVT W5CRT (2)	W5CVT W5CRT (2)	BLUE (2)	A5CR (2)	U5CRT U8CABT (2)	U5CRT U8CABT (2)	U5CRT U8CABT (2)	MECHANICAL: MY29-11 (1) HYDRAULIC: Y644, Y644M, Y644MBH, Y1000, Y1000BH 1 CRIMP	1 - 3/16"	

REV	DATE	DESCRIPTION	ECO	BY	C'H'K.
B	06/12/2013	UPDATED AS PER MARKUP	32072	DK	MA

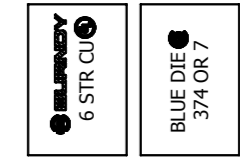

BARREL MARKING

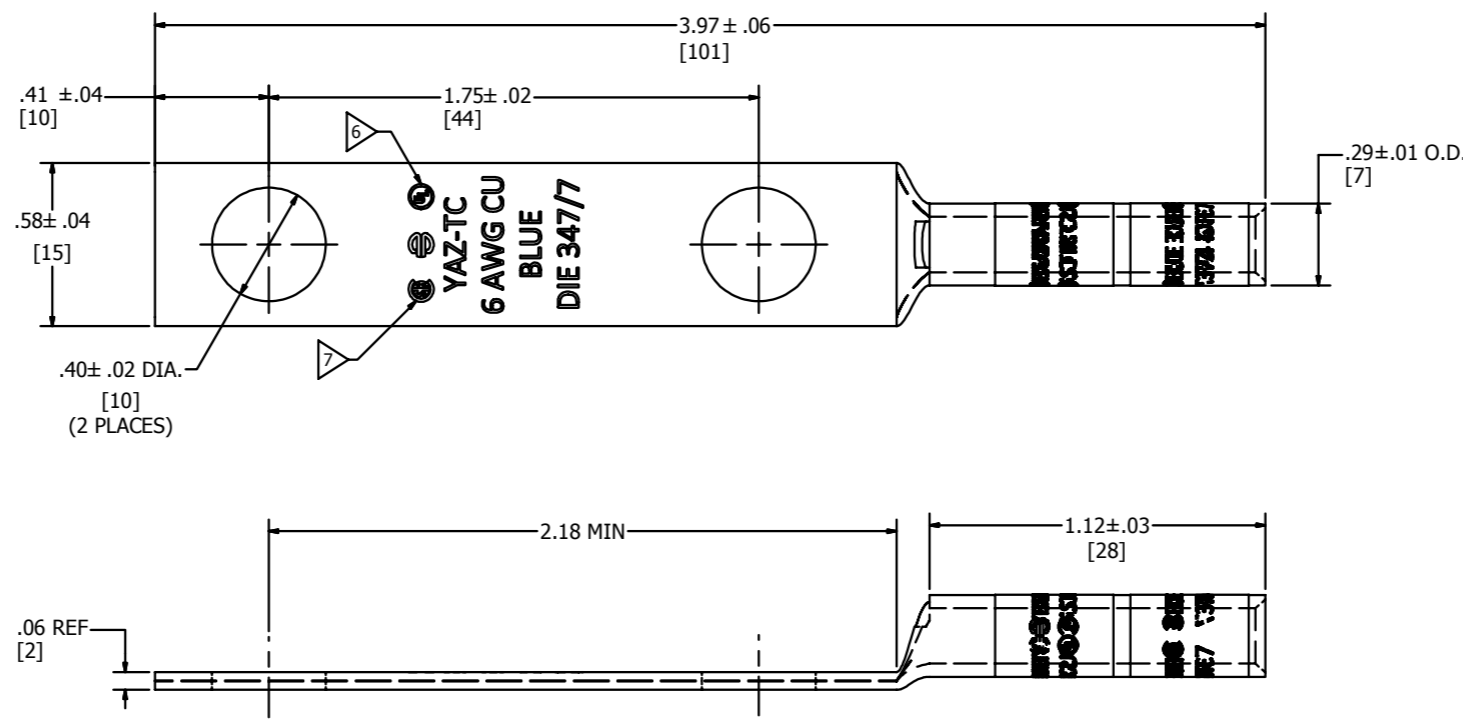
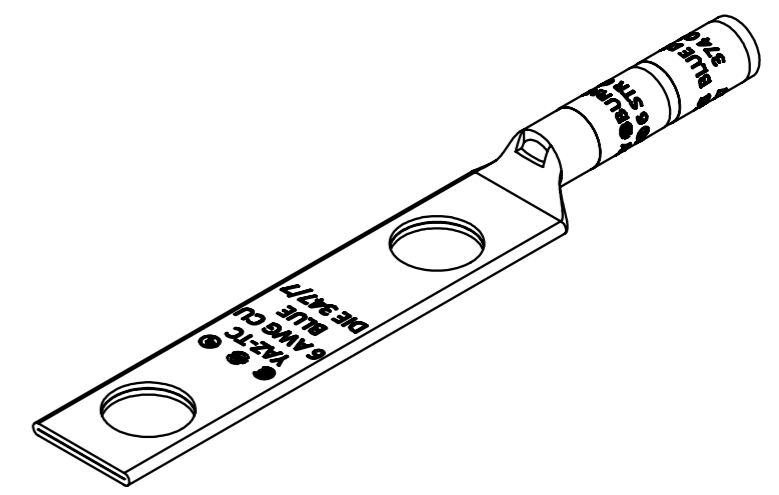

NOTES:

- MATERIAL: COPPER TUBING
- FINISH: TIN PLATED.
- CATALOG # PT6515 ADAPTOR IS REQUIRED TO USE "U" DIES IN Y45 SERIES TOOLS.
- CATALOG # PUADP-1 ADAPTOR IS REQUIRED TO USE "U" DIES IN Y46 SERIES TOOLS.
- PERMANENT DIE IN TOOLING.
- CONNECTORS ARE UL LISTED.
- CONNECTORS ARE CSA CERTIFIED.
- FOR USE BY CUSTOMERS THAT HAVE THIS HYPRESS.™ NO NEW Y34A HYPRESS™ TOOLS ARE BEING PROCESSED.
- DIMENSIONS IN BRACKETS [] ARE IN MILLIMETERS ROUNDED OFF TO THE NEAREST MILLIMETER, UNLESS OTHERWISE NOTED, AND ARE FOR REFERENCE ONLY.

TO ORDER BURNDY® PRODUCTS CALL		HYLUG™	
UNITED STATES 1-800-346-4175 (LONDONDERRY, NH)		ITEM NO: 50009725	
CANADA: 1-800-361-6975 (QUEBEC) 1-800-387-6487 (ALL OTHER PROVINCES)		CAT. NO: YAZ6C2TC38E16	
FOR PRODUCT INFO: http://www.burndy.com		DRAWN BY: V.KAMAL 11/05/2012 CHECKER: J.MICHAUD 10/30/2012 DSN APRVL: J.MICHAUD 10/31/2012 MFG APRVL: M.SMITH 11/02/2012 QA APRVL: T.WATTS 10/30/2012 MKT APRVL: J.SLYVIA 10/30/2012	
		PROJ #:	SIZE
		DOCUMENT TYPE: SALES	50009726
		REL LEVEL: Released	D
		DRAWING NO	REV
		50009726	B
		SHEET 1 OF 1	